



## **MULTIFUNCTIONAL PACKING STATION**

The multifunctional packing station has been specifically designed to solve assist with the most common packaging needs and is optimized for the use of any DUNAPACK packaging system.





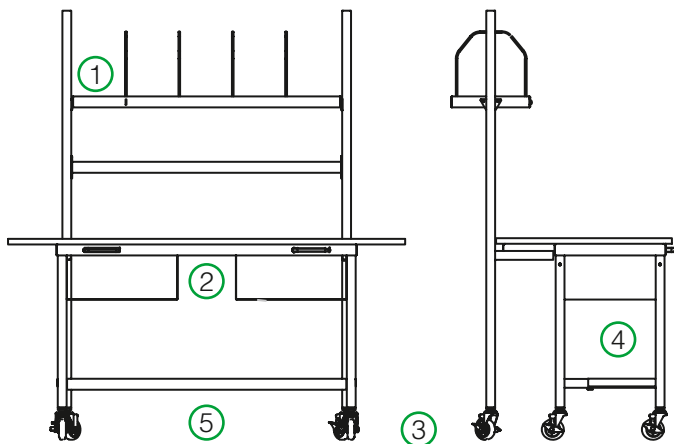

**Features:**

- Upper shelf (1) for storing folded cartons, with comfortable spacious dividers for separating different sizes.
- The back (2) is shaped for drums of DUNAPACK Foam in Place systems, for maximum space reduction
- Supports are on wheels (3) for maximum mobility and convenient replacement of DUNAPACK drums
- Optimized front compartments (4) for bags of Foam in Place BEE pillows.
- Lower shelf (5) designed for Air In Place film reels.



	
180 x 101 x h195 cm	100 kg